

ANSI/ISEA

Z358.1-2014

American National Standard for Emergency Eyewash and Shower Equipment

ANSI/ISEA Z358.1-2014

Revision of

ANSI/ISEA Z358.1-2009

**American National Standard for
Emergency Eyewash and Shower Equipment**

Secretariat

International Safety Equipment Association

Approved January 8, 2015

American National Standards Institute, Inc.

**American
National
Standard**

Approval of an American National Standard requires verification by ANSI that the requirements for due process, consensus, and other criteria for approval have been met by the standards developer. Consensus is established when, in the judgment of the ANSI Board of Standards Review, substantial agreement has been reached by directly and materially affected interests. Substantial agreement means much more than a simple majority, but not necessarily unanimity. Consensus requires that all views and objections be considered, and that a concerted effort be made toward their resolution. The use of American National Standards is completely voluntary; their existence does not in any respect preclude anyone, whether he/she has approved the standards or not, from manufacturing, marketing, purchasing, or using products, processes, or procedures not conforming to the standards. The American National Standards Institute does not develop standards and will in no circumstance give an interpretation of any American National Standard. Moreover, no person shall have the right or authority to issue an interpretation of an American National Standard in the name of the American National Standards Institute. Requests for interpretation should be addressed to the secretariat or sponsor whose name appears on the title page of this standard.

CAUTION NOTICE: This American National Standard may be revised or withdrawn at any time. The procedures of the American National Standards Institute require that action be taken to reaffirm, revise, or withdraw this standard no later than five years from the date of publication. Purchasers of American National Standards may receive current information on all standards by calling or writing the American National Standards Institute.

Published by

**International Safety Equipment Association
1901 North Moore Street, Suite 808, Arlington, Virginia 22209**

Copyright by ISEA

All rights reserved.

No part of this publication may be reproduced in any form, in an electronic retrieval system or otherwise, without the prior written permission of the publisher.

Printed in the United States of America

Foreword (This Foreword is not part of American National Standard ANSI/ISEA Z358.1-2014)

This revision updates ANSI Z358.1-2009 and was prepared by the Emergency Eyewash and Shower Group of the International Safety Equipment Association, whose members are thoroughly knowledgeable in the design, installation, and use of this important safety equipment. The following companies were members of the group at the time of the approval of the standard: Bradley Corporation, Encon Safety Products, FSI International, Guardian Equipment, Honeywell Safety Products, Hughes Safety Showers, Prevor, Inc., Sellstrom Manufacturing, Speakman Company, and VisionAid.

Updates to the 2009 version of the standard are reflected in this document, including improvement in language to emphasize that the location of the fluid flow and pattern delivery for emergency eyewashes and eye/face washes is the critical aspect in designing and installing these devices, rather than the positioning of the nozzles themselves. Additionally, illustrations have been updated to reflect contemporary design configurations that are known to meet the criteria in standard.

Suggestions for the improvement of this standard are welcome. They should be sent to the ISEA, 1901 N. Moore Street, Suite 808, Arlington, VA 22209 or isea@safetysafetyequipment.org.

This standard was processed and approved using consensus procedures prescribed by the American National Standards Institute. The following organizations were contacted prior to the approval of this standard. Inclusion in this list does not necessarily imply that the organization concurred with the submittal of the proposed standard to ANSI.

Acorn Safety
APPA, Leadership in Educational Facilities
Alabama Power Company
Arts, Crafts & Theater Safety Inc.
Atlantic Health
Atlas Industrial Contractors, LLC
BASF Corporation
Baylor Scott & White Health
CalOSHA
Cardinal Health
County of Sacramento
Erdman
Green Conversion Systems
Haws Corporation
International Safety Equipment Association
Intertek

Lawler Manufacturing
Natural Resources Canada
North Carolina Department of Labor
Safety Equipment Institute
Special Graphic Imaging Association
State of Ohio Public Employment Risk Reduction
Program
Syracuse Utilities
UL LLC
University of Georgia
University of Michigan
US Department of the Army
US Department of the Navy
Williams Energy

Contents

SECTION	PAGE
1. Scope	1
2. Purpose.....	1
3. Definitions	1
4. Emergency Showers	2
4.1 Performance of Emergency Showers	2
4.2 Performance of Control Valve	2
4.3 Emergency Shower Enclosures	2
4.4 Testing Procedures for Certification.....	2
4.5 Installation	3
4.6 Maintenance and Training.....	4
5. Eyewash Equipment	4
5.1 Performance of Eyewashes	4
5.2 Performance of Control Valve	4
5.3 Testing Procedures for Certification.....	5
5.4 Installation	5
5.5 Maintenance and Training.....	6
6. Eye/Face Wash Equipment	6
6.1 Performance of Eye/Face Washes	6
6.2 Performance of Control Valve	7
6.3 Testing Procedures for Certification.....	7
6.4 Installation	7
6.5 Maintenance and Training.....	8
7. Combination Units.....	8
7.1 Performance of Combination Units	8
7.2 Performance of Control Valve	8
7.3 Testing Procedures for Certification.....	8
7.4 Installation	8
7.5 Maintenance and Training.....	9
8. Supplemental Equipment.....	9
8.1 Personal Wash Units	9
8.2 Drench Hoses	10

SECTION	PAGE
ILLUSTRATIONS	
Illustration 1	Emergency Shower – Overhead Type 11
Illustration 2	Emergency Shower – Multi-Nozzle 12
Illustration 3	Emergency Shower – Multi-Nozzle with Overhead Fixture 13
Illustration 4	Plumbed Eyewash 14
Illustration 5	Nonpressurized Self-Contained Eyewash..... 15
Illustration 6	Pressurized Self-Contained Eyewash..... 15
Illustration 7	Typical Eyewash Gauge 16
Illustration 8	Eye/Face Wash 16
Illustration 9	Combination Unit 17
Illustration 10	Personal Wash Units 18
Illustration 11	Drench Hose 18
Illustration 12	Drench Hose with Eyewash Attachment..... 18
APPENDICES	
Appendix A – Safety Considerations	19
Appendix B – Installation Considerations	20
REFERENCES.....	22

American National Standard for Emergency Eyewash and Shower Equipment

1. Scope

This standard establishes minimum performance and use requirements for eyewash and shower equipment for the emergency treatment of the eyes or body of a person who has been exposed to hazardous materials. It covers the following types of equipment: emergency showers, eyewashes, eye/face washes, and combination units.

This standard also includes performance and use requirements for personal wash units and drench hoses, which are considered supplemental to emergency eyewash and shower equipment.

2. Purpose

This standard is intended to provide uniform minimum requirements for the performance, use, installation, test procedures, maintenance and training of emergency eyewash and shower equipment.

3. Definitions

For the purpose of this standard, the following terms apply as defined:

certified: A system whereby a certification organization determines that a manufacturer has demonstrated the ability to produce a product that complies with the requirements of this standard, authorizes the manufacturer to use a label on listed products that comply with the requirements of this standard, and establishes a follow-up program conducted by the certification organization as a check on the methods the manufacturer uses to determine continued compliance of labeled and listed products with the requirements of this standard.

certification organization: An independent third party organization that determines product compliance with the requirements of this standard with a labeling/listing/follow-up program.

combination unit: An interconnected assembly of emergency equipment supplied by a single source of flushing fluid.

drench hose: A supplemental device consisting of a flexible hose connected to a flushing fluid supply and used to provide fluid to irrigate and flush face and body areas.

emergency shower: A device specifically designed and intended to deliver flushing fluid in sufficient volume to cause that fluid to cascade over the entire body.

eye/face wash: A device used to provide fluid to irrigate and flush both the face and the eyes simultaneously.

eyewash: A device used to provide fluid to irrigate and flush the eyes.

flow pressure: The pressure in the water supply pipe near the water outlet while the faucet or outlet is fully open and flowing.

flushing fluid: Potable water, preserved water, preserved buffered saline solution or other medically acceptable solution manufactured and labeled in accordance with applicable government regulations.

flushing fluid column: The dispersion pattern of flushing fluid which is created by an emergency shower and meets the standard's prescribed coverage requirements. This pattern can be achieved by a variety of design configurations.

freeze protected equipment: Equipment designed to allow the emergency device to operate under freezing conditions.

freeze protection: A means to protect flushing fluid in an apparatus from freezing and rendering it inoperable. This can be achieved through several means including mechanical valves and electrical heat tracing.

hazardous material: Any substance or compound that has the capability of producing

adverse effects on the health and safety of humans.

personal wash: A supplementary device that supports plumbed and/or self-contained units, by delivering immediate flushing fluid to the eyes or body.

plumbed: A term used to describe equipment that is connected to a continual source of potable water.

potable water: Water that is suitable for drinking.

self-closing valve: A valve that closes automatically when released by the user.

self-contained: A term used to describe a stand-alone device containing flushing fluid.

tepid: A flushing fluid temperature conducive to promoting a minimum 15 minute irrigation period. A suitable range is 16 - 38° C (60 -100° F). (See Appendix B6).

valve actuator: A device connected to the valve to facilitate its operation.

4. Emergency Showers (See Illustrations 1, 2, 3)

4.1 Performance of Emergency Showers

4.1.1 A means shall be provided to ensure that a controlled flow of flushing fluid is provided at a velocity low enough to be non-injurious to the user.

4.1.2 Emergency showers shall be capable of delivering flushing fluid at a minimum of 75.7 liters per minute (20 gpm) for a minimum of 15 minutes. If shut off valves are installed in the supply line for maintenance purposes, provisions shall be made to prevent unauthorized shut off.

4.1.3 Emergency showers shall provide a flushing fluid column that is at least 208.3 cm (82 in.) and not more than 243.8 cm (96 in.) in height from the surface on which the user stands.

4.1.4 The spray pattern shall have a minimum diameter of 50.8 cm (20 in.) at 152.4 cm (60 in.) above the surface on which the user stands, and the center of the spray pattern shall be located at

least 40.6 cm (16 in.) from any obstruction. The flushing fluid shall be substantially dispersed throughout the pattern.

4.1.5 Emergency showers shall be designed, manufactured and installed in such a manner that, once activated, they can be used without requiring the use of the operator's hands.

4.1.6 Emergency showers shall be constructed of materials that will not corrode in the presence of the flushing fluid. Stored flushing fluid shall be protected against airborne contaminants.

4.2 Performance of Control Valve

The valve shall remain open without the use of the operator's hands until intentionally closed. The valve shall be simple to operate and shall go from "off" to "on" in 1 second or less. The valve shall be resistant to corrosion. Manual or automatic actuators shall be easy to locate and readily accessible to the user. Valve actuators shall be located not more than 173.3 cm (69 in.) above the level on which the user stands.

4.3 Emergency Shower Enclosures

If used, enclosures shall provide for a minimum unobstructed area of 86.4 cm (34 in.) in diameter.

4.4 Testing Procedures for Certification

4.4.1 Plumbed Emergency Showers

Plumbed emergency showers shall be certified as follows:

(1) Connect a flowmeter to the unit to be tested or provide other means of measuring flushing fluid flow.

(2) Connect the unit per the manufacturer's specifications to a flushing fluid supply at a flow pressure of 207 kPa +3.4 kPa -0 kPa (30 psi +0.5 psi -0 psi).

(3) Open the valve on the unit and verify that it fully opens in one second or less and that it stays open.

(4) Determine that flushing fluid is substantially dispersed throughout the pattern. The flushing fluid column pattern

shall be at least 208 cm (82 in.) and no more than 243.8 cm (96 in.) from the surface on which the user stands. Measure the diameter of the flushing fluid pattern 152.4 cm (60 in.) above the surface on which the user stands. The diameter shall be a minimum of 50.8 cm (20 in.). Throughout the 15-minute test, verify that the flow rate is a minimum of 75.7 liters per minute (20 gpm).

4.4.2 Self-contained Emergency Showers

Self-contained emergency showers shall be certified as follows:

- (1) Fill the unit with flushing solution.
- (2) Connect a flowmeter to the unit to be tested or provide other means of measuring flushing fluid flow.
- (3) Open the valve on the unit and verify that it fully opens in one second or less and that it stays open.
- (4) Determine that flushing fluid is substantially dispersed throughout the pattern. The flushing fluid column pattern shall be at least 208 cm (82 in.) and not more than 243.8 cm (96 in.) from the surface on which the user stands. Measure the diameter of the flushing fluid pattern 152.4 cm (60 in.) above the surface on which the user stands. The diameter shall be a minimum of 50.8 cm (20 in.). Throughout the 15-minute test, verify that the flow rate is a minimum of 75.7 liters per minute (20 gpm).

4.5 Installation

It is the installer's responsibility to ensure that emergency showers shall:

- 4.5.1 Be assembled and installed in accordance with the manufacturer's instructions, including flushing fluid delivery requirements.
- 4.5.2 Be in accessible locations that require no more than 10 seconds to reach. The emergency shower shall be located on the same level as the hazard and the path of travel shall be free of obstructions that may inhibit its immediate use. (See Appendix B5)

4.5.3 Be located in an area identified with a highly visible sign positioned so the sign shall be visible within the area served by the emergency shower. The area around the emergency shower shall be well-lit.

4.5.4 Be positioned so that the shower pattern is dispersed such that the top of the flushing fluid column is at least 208.3 cm (82 in.) and not more than 243.8 cm (96 in.) from the surface on which the user stands. The center of the spray shall be at least 40.6 cm (16 in.) from any obstruction.

4.5.5 Be connected to a supply of flushing fluid per the manufacturer's installation instructions to produce the required spray pattern for a minimum period of 15 minutes. Where the possibility of freezing conditions exists, the emergency shower shall be protected from freezing or freeze-protected equipment shall be installed. If shut off valves are installed in the shower line for maintenance purposes, provisions shall be made to prevent unauthorized shut off.

4.5.6 Deliver tepid flushing fluid. In circumstances where chemical reaction is accelerated by flushing fluid temperature, a facilities safety/health advisor should be consulted for the optimum temperature for each application.

4.5.7 When the plumbed emergency shower is installed, its performance shall be verified in accordance with the following procedures:

- (1) With the unit correctly connected to the flushing fluid source and the valve(s) closed, visually check the piping connections for leaks.
- (2) Open the valve to the full open position. The valve shall remain open without requiring further use of the operator's hands.
- (3) With the valve in the fully opened position, measure the diameter of the spray pattern. It shall be a minimum of 50.8 cm (20 in.) at 152.4 cm (60 in.) above the standing surface. The flushing fluid shall be substantially dispersed throughout the pattern.

(4) Using the flowmeter or other means, determine that the rate of flow is at least 75.7 liters per minute (20 gpm).

(5) Using a temperature gauge or other means, determine that the flushing fluid is tepid.

4.5.8 When the self-contained emergency shower is installed, its installation shall be verified in accordance with manufacturer's instructions.

4.6 Maintenance and Training

4.6.1 Manufacturers shall provide operation, inspection and maintenance instructions with emergency shower equipment. Instructions shall be readily accessible to maintenance and training personnel.

4.6.2 Plumbed emergency showers shall be activated weekly for a period long enough to verify operation and ensure that flushing fluid is available. (See Appendix B7)

4.6.3 Self-contained emergency showers shall be visually checked weekly to determine if flushing fluid needs to be changed or supplemented. Such inspection shall be conducted in accordance with manufacturer's instructions.

4.6.4 Employees who may be exposed to hazardous materials shall be instructed in the location and proper use of emergency showers.

4.6.5 All emergency showers shall be inspected annually to assure conformance with Section 4.5 requirements of this standard.

5. Eyewash Equipment (See Illustrations 4, 5, 6)

5.1 Performance of Eyewashes

5.1.1 A means shall be provided to ensure that a controlled flow of flushing fluid is provided to both eyes simultaneously at a velocity low enough to be non-injurious to the user.

5.1.2 The eyewash shall be designed and positioned in such a way as to pose no hazard to the user.

5.1.3 Nozzles and flushing fluid units shall be protected from airborne contaminants. Whatever means is used to afford such protection, its removal shall not require a separate motion by the operator when activating the unit.

5.1.4 Eyewashes shall be designed, manufactured and installed in such a manner that, once activated, they can be used without requiring the use of the operator's hands.

5.1.5 Eyewashes shall be constructed of materials that will not corrode in the presence of the flushing fluid.

5.1.6 Eyewashes shall be capable of delivering flushing fluid to the eyes not less than 1.5 liters per minute (0.4 gpm) for 15 minutes. If shut off valves are installed in the supply line for maintenance purposes, provisions shall be made to prevent unauthorized shut off.

5.1.7 Eyewashes shall be designed to provide enough room to allow the eyelids to be held open with the hands while the eyes are in the flushing fluid stream.

5.1.8 Eyewashes shall provide flushing fluid to both eyes simultaneously. A test gauge for making determination of a suitable eyewash pattern shall be a minimum 10.16 cm (4 in.) in length with two sets of parallel lines equidistant from the center (See Illustration 7). The interior set of lines shall be 3.18 cm (1.25 in.) apart and the exterior lines shall be 8.26 cm (3.25 in.) apart. Place the gauge in the stream of the eyewash. The flushing fluid shall cover the areas between the interior and exterior lines of the gauge at some point less than 20.3 cm (8 in.) above the eyewash nozzle(s).

5.2 Performance of Control Valve

The valve shall remain open without the use of the operator's hands until intentionally closed. The valve shall be simple to operate and shall go from "off" to "on" in 1 second or less. The valve shall be resistant to corrosion. Manual or automatic actuators shall be easy to locate and readily accessible to the user.

5.3 Testing Procedures for Certification

5.3.1 Plumbed Eyewashes

Plumbed eyewashes shall be certified as follows:

- (1) Connect a flowmeter to the unit to be tested, or provide other means of measuring flushing fluid flow.
- (2) Connect the unit to a flushing fluid supply per the manufacturer's instructions at a flow pressure of 207 kPa +3.4 kPa -0 kPa (30 psi +0.5 psi -0 psi).
- (3) Open the valve on the eyewash and verify that it fully opens in one second or less and that it stays open.
- (4) Throughout the 15 minute test, ensure that the unit is capable of delivering a minimum of 1.5 liters per minute (0.4 gpm) and that the flushing fluid covers the areas between the interior and exterior lines of the gauge at some point less than 20.3 cm (8 in.) above the eyewash nozzle(s) (Illustration 7).

5.3.2 Self-contained Eyewashes

Self-contained eyewashes shall be certified as follows:

- (1) Set up the unit per the manufacturer's instructions.
- (2) Fill the unit with flushing fluid or with the pre-packaged fluid provided by the manufacturer.
- (3) Activate the unit and verify that it can be activated in one second or less and that it stays activated.
- (4) Throughout the 15 minute test, ensure that the eyewash is capable of delivering a minimum of 1.5 liters per minute (0.4 gpm) and that the flushing fluid covers the areas between the interior and exterior lines of the gauge at some point less than 20.3 cm (8 in.) above the eyewash nozzle(s) (Illustration 7).

5.4 Installation

It is the installer's responsibility to ensure that eyewashes shall:

- 5.4.1 Be assembled and installed in accordance with the manufacturer's instructions, including flushing fluid delivery requirements.
- 5.4.2 Be in accessible locations that require no more than 10 seconds to reach. The eyewash shall be located on the same level as the hazard and the path of travel shall be free of obstructions that may inhibit its immediate use. (See Appendix B5)
- 5.4.3 Be located in an area identified with a highly visible sign positioned so the sign shall be visible within the area served by the eyewash. The area around the eyewash shall be well-lit.
- 5.4.4 Be arranged such that the flushing fluid flow pattern as described in Section 5.1.8 is not less than 83.8 cm (33 in.) and no greater than 134.6 cm (53 in.) from the surface on which the user stands and 15.3 cm (6 in.) minimum from the wall or the nearest obstruction.
- 5.4.5 Be connected to a supply of flushing fluid per the manufacturer's installation instructions to produce the required spray pattern for a minimum period of 15 minutes. Where the possibility of freezing conditions exists, the eyewash shall be protected from freezing or freeze-protected equipment shall be installed. If shut off valves are installed in the supply line for maintenance purposes, provisions shall be made to prevent unauthorized shut off.
- 5.4.6 Deliver tepid flushing fluid. In circumstances where chemical reaction is accelerated by flushing fluid temperature, a facilities safety/health advisor should be consulted for the optimum temperature for each application.
- 5.4.7 When the plumbed eyewash is installed, its performance shall be verified in accordance with the following procedures:
 - (1) With the unit correctly connected to the flushing fluid source and the valve(s) closed, visually check the piping connections for leaks.

(2) Open the valve to the full open position. The valve shall remain open without requiring further use of the operator's hands.

(3) With the valve in the fully open position, make sure that both eyes will be washed simultaneously at a velocity low enough to be non-injurious to the user.

(4) Using the flowmeter or other means, determine that the rate of flow is at least 1.5 liters per minute (0.4 gpm). A test gauge similar to the one pictured in Illustration 7 can be used to verify minimum flow characteristics.

(5) Using a temperature gauge or other means, determine that the flushing fluid is tepid.

5.4.8 When the self-contained eyewash is installed, its installation shall be verified in accordance with manufacturer's instructions.

5.5 Maintenance and Training

5.5.1 Manufacturers shall provide operation, inspection and maintenance instructions with eyewashes. Instructions shall be readily accessible to maintenance and inspection personnel.

5.5.2 Plumbed eyewashes shall be activated weekly for a period long enough to verify operation and ensure that flushing fluid is available. (See Appendix B7)

5.5.3 Self-contained eyewashes shall be visually checked weekly to determine if flushing fluid needs to be changed or supplemented. Such inspection shall be conducted in accordance with manufacturer's instructions.

5.5.4 Employees who may be exposed to hazardous materials shall be instructed in the location and proper use of emergency eyewashes.

5.5.5 All eyewashes shall be inspected annually to assure conformance with Section 5.4 requirements of this standard.

6. Eye/Face Wash Equipment (See Illustration 8)

6.1 Performance of Eye/Face Washes

6.1.1 A means shall be provided to ensure that a controlled flow of flushing fluid is provided to both eyes and face simultaneously at a velocity low enough to be non-injurious to the user.

6.1.2 Eye/face washes shall be designed and positioned in such a way as to pose no hazard to the user.

6.1.3 Nozzles and flushing fluid units shall be protected from airborne contaminants. Whatever means is used to afford such protection, its removal shall not require a separate motion by the operator when activating the unit.

6.1.4 Eye/face washes shall be designed, manufactured and installed in such a manner that, once activated, they can be used without requiring the use of the operator's hands.

6.1.5 Eye/face washes shall be constructed of materials that will not corrode in the presence of the flushing fluid.

6.1.6 Eye/face washes shall be capable of delivering flushing fluid to the eyes and face not less than 11.4 liters per minute (3.0 gpm) for 15 minutes. If shut off valves are installed in the line for maintenance purposes, provisions shall be made to prevent unauthorized shut off.

6.1.7 Eye/face washes shall be designed to provide enough room to allow the eyelids to be held open with the hands while the eyes and face are in the flushing fluid stream.

6.1.8 Eye/face washes shall provide flushing fluid to both eyes simultaneously. A test gauge for making determination of a suitable eyewash pattern shall be a minimum 10.16 cm (4 in.) in length with two sets of parallel lines equidistant from the center (See Illustration 7). The interior set of lines shall be 3.18 cm (1.25 in.) apart and the exterior lines shall be 8.26 cm (3.25 in.) apart. Place the gauge in the stream of the eyewash. The flushing fluid shall cover the areas between the interior and exterior lines of the gauge at some point less than 20.3 cm (8 in.) above the eye/face wash nozzle(s).

6.2 Performance of Control Valve

The valve shall remain open without the use of the operator's hands until intentionally closed. The valve shall be simple to operate and shall go from "off" to "on" in 1 second or less. The valve shall be resistant to corrosion. Manual or automatic actuators shall be easy to locate and readily accessible to the user.

6.3 Testing Procedures for Certification

6.3.1 Plumbed Eye/Face Washes

Plumbed eye/face washes shall be certified as follows:

- (1) Connect a flowmeter to the unit to be tested, or provide other means of measuring flushing fluid flow.
- (2) Connect the unit to a flushing fluid supply per the manufacturer's instructions at a flow pressure of 207 kPa +3.4 kPa -0 kPa (30 psi +0.5 psi -0 psi).
- (3) Open the valve on the unit and verify that it opens in one second and stays open.
- (4) Throughout the 15 minute test, ensure that the unit is capable of delivering a minimum of 11.4 liters per minute (3.0 gpm) and that the flushing fluid covers the areas between the interior and exterior lines of the gauge at some point less than 20.3 cm (8 in.) above the eye/face wash nozzle(s) (Illustration 7).

6.3.2 Self-contained Eye/Face Washes

Self-contained eye/face washes shall be certified as follows:

- (1) Set up the unit per the manufacturer's instructions.
- (2) Fill the unit with flushing fluid or with the pre-packaged fluid provided by the manufacturer.
- (3) Activate the unit and verify that it can be activated in one second or less and that it stays activated.
- (4) Throughout the 15 minute test, ensure that the unit is capable of delivering a

minimum of 11.4 liters per minute (3.0 gpm) and that the flushing fluid covers the areas between the interior and exterior lines of the gauge at some point less than 20.3 cm (8 in.) above the eye/face wash nozzle(s) (Illustration 7).

6.4 Installation

It is the installer's responsibility to ensure that eye/face washes shall:

6.4.1 Be assembled and installed in accordance with the manufacturer's instructions, including flushing fluid delivery requirements.

6.4.2 Be in accessible locations that require no more than 10 seconds to reach. The eye/face wash shall be located on the same level as the hazard and the path of travel shall be free of obstructions that may inhibit the immediate use of the equipment. (See Appendix B5)

6.4.3 Be located in an area identified with a highly visible sign positioned so the sign shall be visible within the area served by the eye/face wash. The area around the eye/face wash shall be well-lit.

6.4.4 Be arranged such that the flushing fluid flow pattern as described in Section 6.1.8 is not less than 83.8 cm (33 in.) and no greater than 134.6 cm (53 in.) from the level on which the user stands and 15.3 cm (6 in.) minimum from the wall or nearest obstruction.

6.4.5 Be connected to a supply of flushing fluid per the manufacturer's installation instructions to produce the required spray pattern for a minimum period of 15 minutes. Where the possibility of freezing conditions exists, the eye/face wash shall be protected from freezing or freeze-protected equipment shall be installed. If shut off valves are installed in the supply line for maintenance purposes, provisions shall be made to prevent unauthorized shut off.

6.4.6 Deliver tepid flushing fluid. In circumstances where chemical reaction is accelerated by flushing fluid temperature, a facilities safety/health advisor should be consulted for the optimum temperature for each application. (See Appendix B6)

6.4.7 When the plumbed eye/face wash is installed, its performance shall be verified in accordance with the following procedures:

(1) With the unit correctly connected to the flushing fluid source and the valve(s) closed, visually check the piping connections for leaks.

(2) Open the valve to the full open position. The valve shall remain open without requiring further use of the operator's hands.

(3) With the valve in the fully opened position make sure that both eyes and face will be washed simultaneously at a velocity low enough to be non-injurious to the user.

(4) Using the flowmeter or other means, determine that the rate of flow is at least 11.4 liters per minute (3.0 gpm). A test gauge similar to the one pictured in Illustration 7 can be used to verify minimum flow characteristics.

(5) Using a temperature gauge or other means, determine that the flushing fluid is tepid.

6.4.8 When the self-contained eye/face wash is installed, its installation shall be verified in accordance with manufacturer's instructions.

6.5 Maintenance and Training

6.5.1 Manufacturers shall provide operation, inspection and maintenance instructions with eye/face washes. Instructions shall be readily accessible to maintenance and inspection personnel.

6.5.2 Plumbed eye/face washes shall be activated weekly for a period long enough to verify operation and ensure that flushing fluid is available. (See Appendix B7)

6.5.3 Self-contained eye/face washes shall be visually checked weekly to determine if flushing fluid needs to be changed or supplemented. Such inspection shall be conducted in accordance with manufacturer's instructions.

6.5.4 Employees who may be exposed to hazardous materials shall be instructed in the location and proper use of eye/face washes.

6.5.5 All eye/face washes shall be inspected annually to assure conformance with Section 6.4 requirements of this standard.

7. Combination Units (See Illustration 9)

7.1 Performance of Combination Units

Components of combination units shall operate individually and simultaneously in accordance with the following sections:

7.1.1 Emergency showers shall meet the performance requirements of Section 4.

7.1.2 Eyewashes shall meet the performance requirements of Section 5.

7.1.3 Eye/face washes shall meet the performance requirements of Section 6.

7.1.4 Drench hoses shall meet the performance requirements of Section 8.2 at the pressure and flow specified by the manufacturer.

NOTE: The eyewash or eye/face wash section of a combination unit is not considered an "obstruction" in this context to allow for simultaneous use of emergency shower and eyewash equipment.

7.2 Performance of Control Valve

Each valve shall meet the applicable requirements of Sections 4, 5, 6, and 8.2.2, depending on which of the components listed in Section 7.1 are included.

7.3 Testing Procedures for Certification

Each part of the combination unit shall be certified individually and when activated simultaneously be in accordance with the procedures outlined in Sections 4, 5, 6 and 8.2, depending on which of the components listed in Section 7.1 are included.

7.4 Installation

It is the installer's responsibility to ensure that combination units shall:

7.4.1 Be assembled and installed in accordance with the manufacturer's instructions, including flushing fluid delivery requirements.

7.4.2 Be in accessible locations that require no more than 10 seconds to reach. The combination unit shall be located on the same level as the hazard and the path of travel shall be free of obstructions that may inhibit its immediate use. (See Appendix B5)

7.4.3 Be located in an area identified with a highly visible sign positioned so the sign shall be visible within the area served by the combination unit. The area around the combination unit shall be well-lit.

7.4.4 Be connected to a system capable of supplying adequate flushing fluid to meet the requirements of each component as outlined in Sections 4, 5, and 6 when all components are operated simultaneously. Combination unit components shall be positioned so that components may be used simultaneously by the same user. Where the possibility of freezing conditions exists, combination units shall be protected from freezing or freeze-protected equipment shall be installed.

7.4.5 Deliver tepid flushing fluid. In circumstances where chemical reaction is accelerated by flushing fluid temperature, a facilities safety/health advisor should be consulted for the optimum temperature for each application. (See Appendix B6)

7.4.6 When the combination unit is installed, its performance shall be verified in accordance with the following procedures:

(1) With the unit correctly connected to the flushing fluid source and the valve(s) closed, visually check the piping connections for leaks.

(2) Open the emergency shower and eyewash or eye/face wash valves to the full open position. The valves shall remain open without requiring further use of the operator's hands.

(3) Activate the valves and check the performance of the emergency shower, eyewash and eye/face wash valves as described in Sections 4.5.7, 5.4.7 and 6.4.7 respectively, while operating simultaneously.

(4) Using a temperature gauge or other means, determine that the flushing fluid is tepid.

NOTE: Where hand-held drench hoses are part of the combination unit, the flow and pressure shall be specified by the manufacturer.

7.5 Maintenance and Training

7.5.1 Manufacturers shall provide operation, inspection and maintenance instructions with combination units. Instructions shall be readily accessible to maintenance and inspection personnel.

7.5.2 Plumbed combination units shall be activated weekly for a period long enough to verify operation and ensure that flushing fluid is available. (See Appendix B7)

7.5.3 Self-contained combination units shall be visually checked weekly to determine if flushing fluid needs to be changed or supplemented. Such inspection shall be conducted in accordance with manufacturer's instructions.

7.5.4 Employees who may be exposed to hazardous materials shall be instructed in the location and proper use of combination units.

7.5.5 All combination units shall be inspected annually to assure conformance with Section 7.4 requirements of this standard.

8. Supplemental Equipment

The supplemental equipment listed below shall provide immediate flushing to support plumbed and self-contained emergency eyewash and shower equipment but shall not replace them.

8.1. Personal Wash Units (See Illustration 10)

8.1.1 Performance of Personal Wash Units

8.1.1.1 Personal wash units shall have the capacity to deliver immediate flushing fluid without being injurious to the user. Personal wash units do not meet the criteria of plumbed or self-contained eyewash equipment.

8.1.1.2 In circumstances where chemical reaction is accelerated by flushing fluid temperature, a facilities safety/health advisor should be consulted for the optimum temperature for each application. (See Appendix B6)

8.1.2 Installation

Personal wash units shall be protected from freezing and shall not be exposed to ambient temperatures exceeding 38 ° C (100 ° F).

8.1.3 Maintenance, Training and Storage

8.1.3.1 Manufacturers shall provide operation, inspection and maintenance instructions with personal wash units. Instructions shall be readily accessible to maintenance and inspection personnel.

8.1.3.2 All personal wash units shall be inspected and maintained in accordance with manufacturer's instructions and shall meet applicable regulatory requirements.

8.1.3.3 Employees shall be instructed in the location, proper use and application of personal wash units.

8.1.2.4 All personal wash units shall be inspected annually to assure conformance with Section 8.1 requirements of this standard.

8.2 Drench Hoses (See Illustrations 11, 12)

8.2.1 Performance of Drench Hoses

Drench hoses shall be designed to provide a controlled flow of flushing fluid to a portion of the body at a velocity low enough to be non-injurious to the user.

NOTE: A drench hose may be considered an eyewash or eye/face wash if the device meets the performance requirements of Section 5 and/or Section 6.

8.2.2 Performance of Control Valve

The valve shall be simple to operate and shall go from "off" to "on" in 1 second or less. The valve shall be resistant to corrosion. Manual or automatic actuators shall be easy to locate and be readily accessible to the user.

8.2.3 Installation

It is the installer's responsibility to ensure that drench hoses shall:

8.2.3.1 Be assembled and installed in accordance with the manufacturer's instructions.

8.2.3.2 Be located in an area identified with a highly visible sign positioned so the sign shall be visible within the area served by the drench hose. The area around the drench hose shall be well-lit, and free of debris that may inhibit its immediate use.

8.2.3.3 Be connected to a supply of flushing fluid. Where the possibility of freezing conditions exists, drench hoses shall be protected from freezing or freeze-protected equipment shall be installed. If shut off valves are installed in the supply line for maintenance purposes, provisions shall be made to prevent unauthorized shut off.

8.2.3.4 Deliver tepid flushing fluid. In circumstances where chemical reaction is accelerated by flushing fluid temperature, a facilities safety/health advisor should be consulted for the optimum temperature for each application.

8.2.4 Maintenance and Training

8.2.4.1 Manufacturers shall provide operation, inspection and maintenance instructions with drench hoses. Instructions shall be readily accessible to maintenance and inspection personnel.

8.2.4.2 Plumbed drench hoses shall be activated weekly for a period long enough to verify operation and ensure that flushing fluid is available.

8.2.4.3 Self-contained drench hoses shall be visually checked weekly to determine if flushing fluid needs to be changed or supplemented. Such inspection shall be conducted in accordance with manufacturer's instructions.

8.2.4.4 Employees who may be exposed to hazardous materials shall be instructed in the location and proper use of drench hoses.

8.2.4.5 All drench hoses shall be inspected annually to assure conformance with Section 8.2.3 requirements of this standard.

Illustrations

The illustrations included in ANSI/ISEA Z358.1-2014 are included as examples of configurations capable of meeting the criteria set forth in this standard. Other configurations may be acceptable if they meet the performance criteria established in this standard.

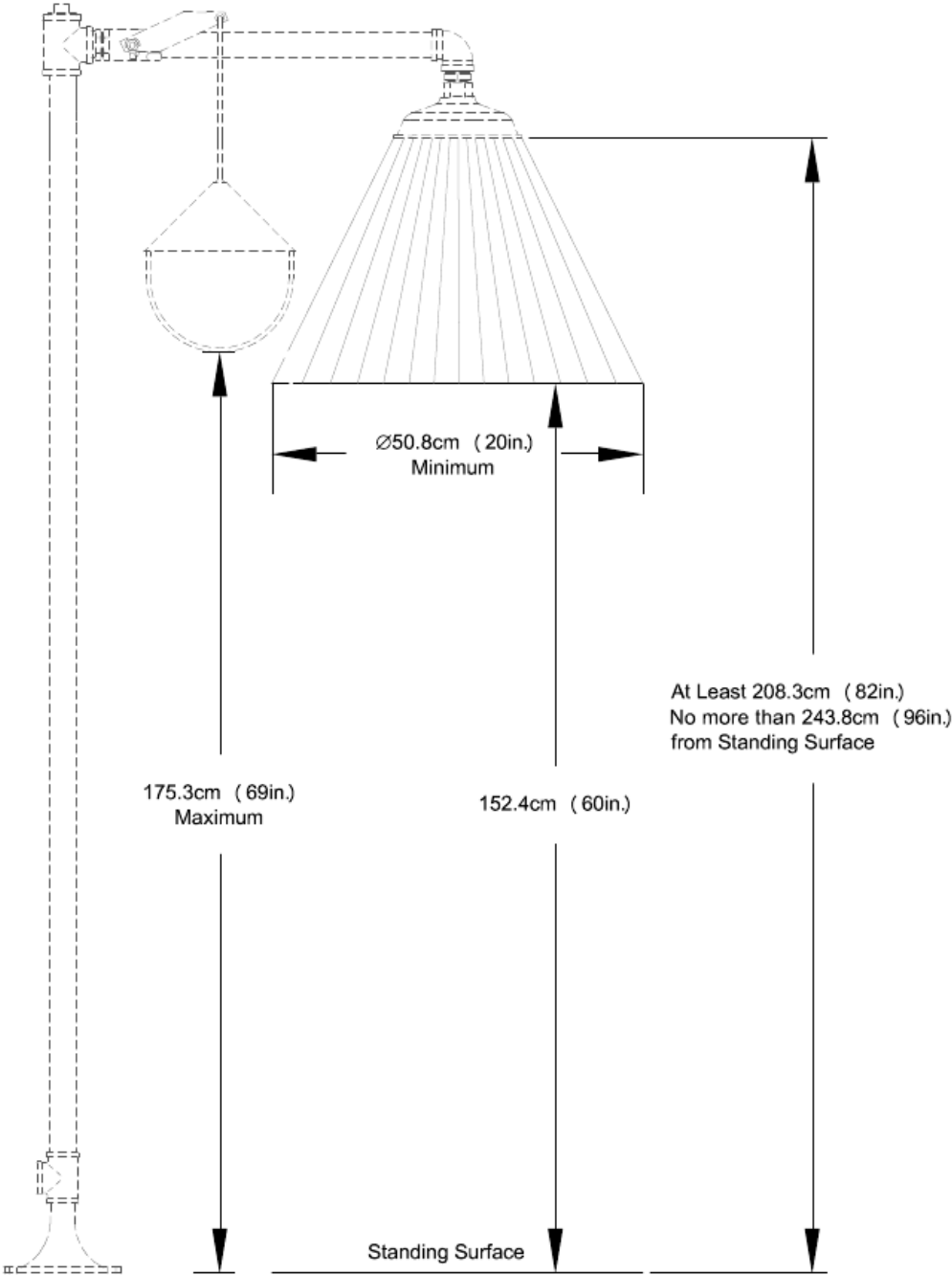

Illustration 1
Emergency Shower – Overhead Type

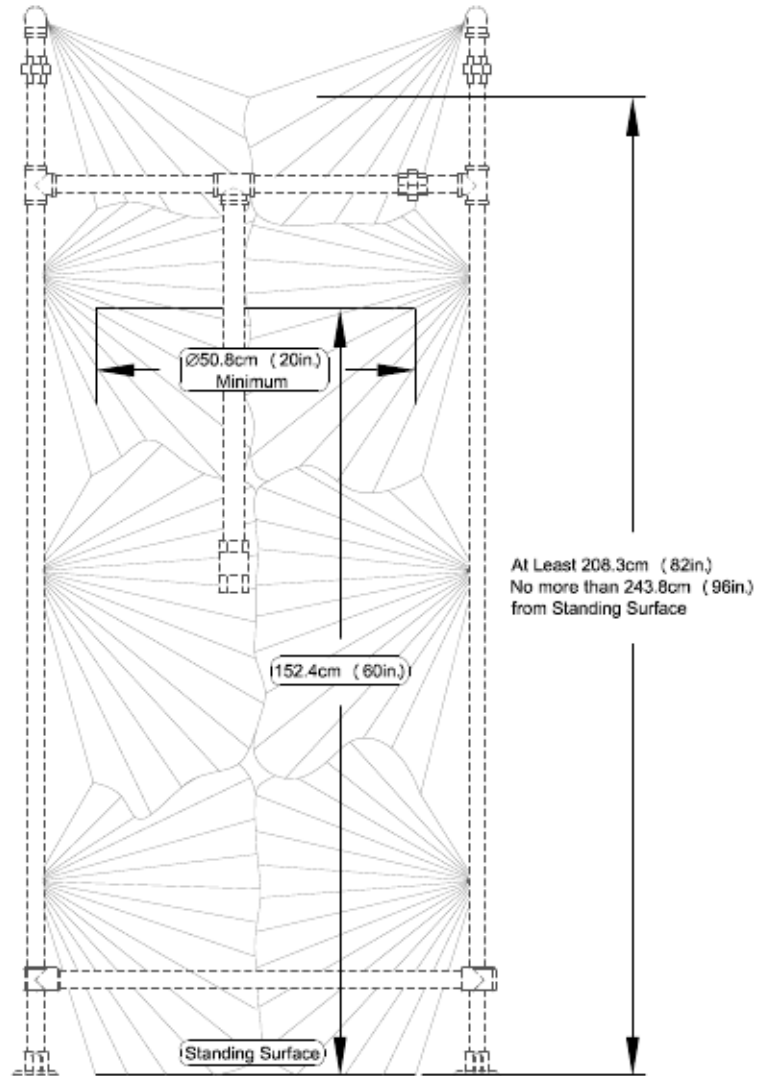

Illustration 2
Emergency Shower – Multi-Nozzle

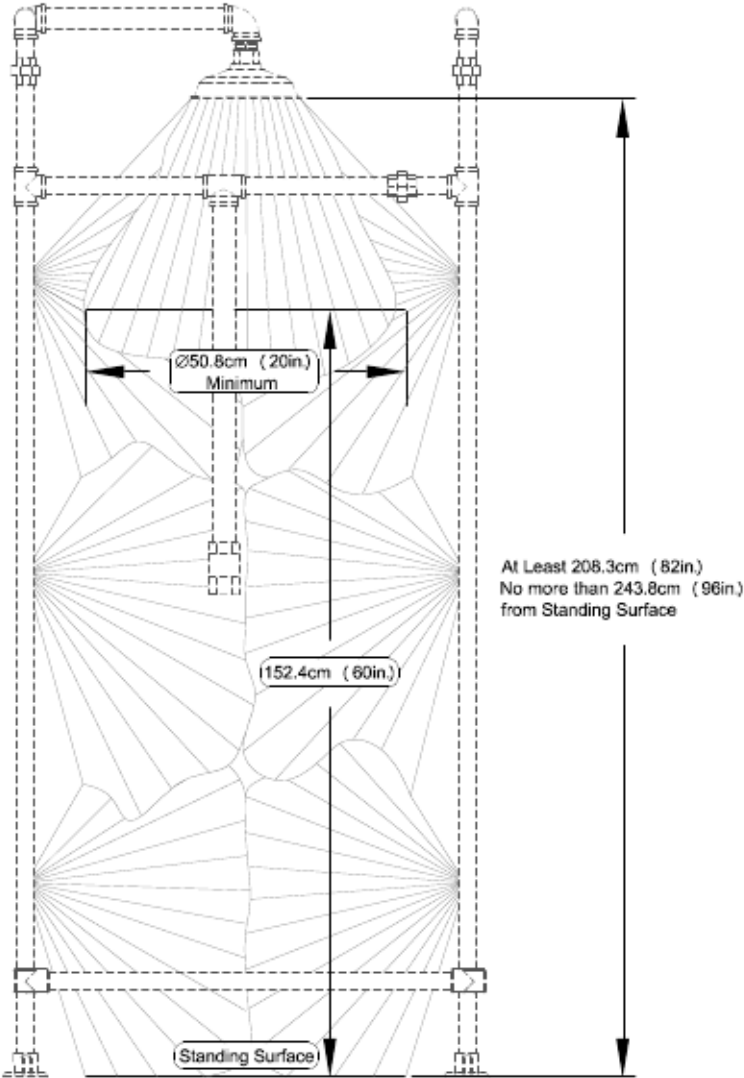

Illustration 3
Emergency Shower – Multi-Nozzle with Overhead Fixture

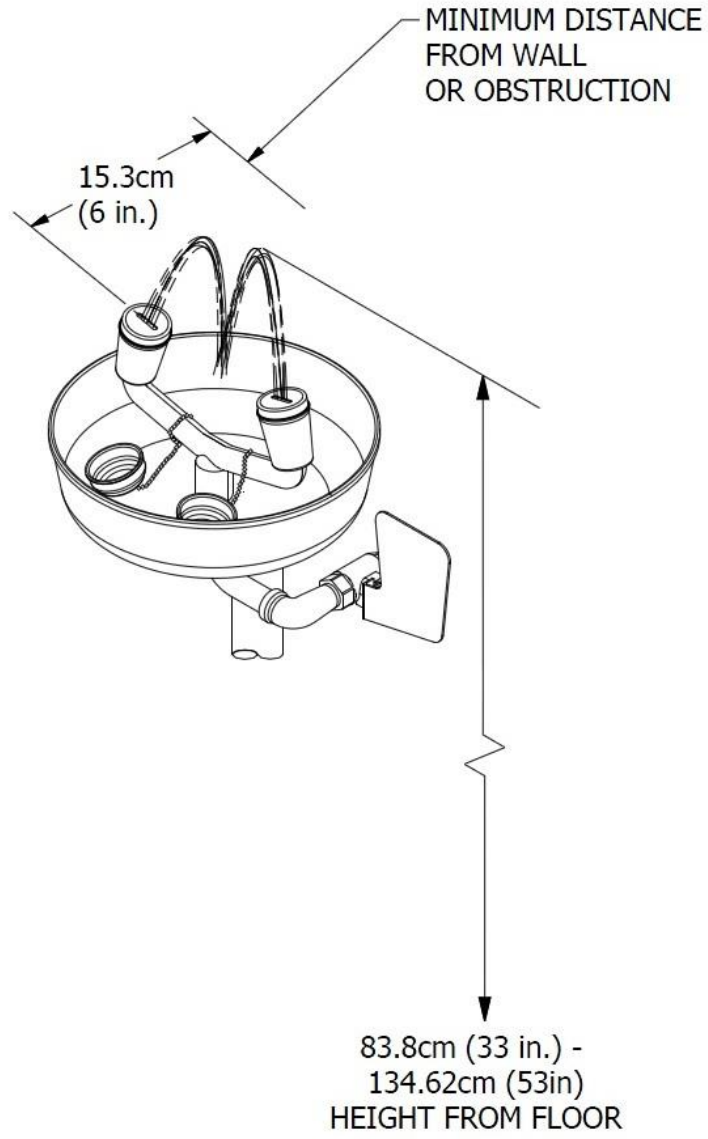

Illustration 4
Plumbed Eyewash

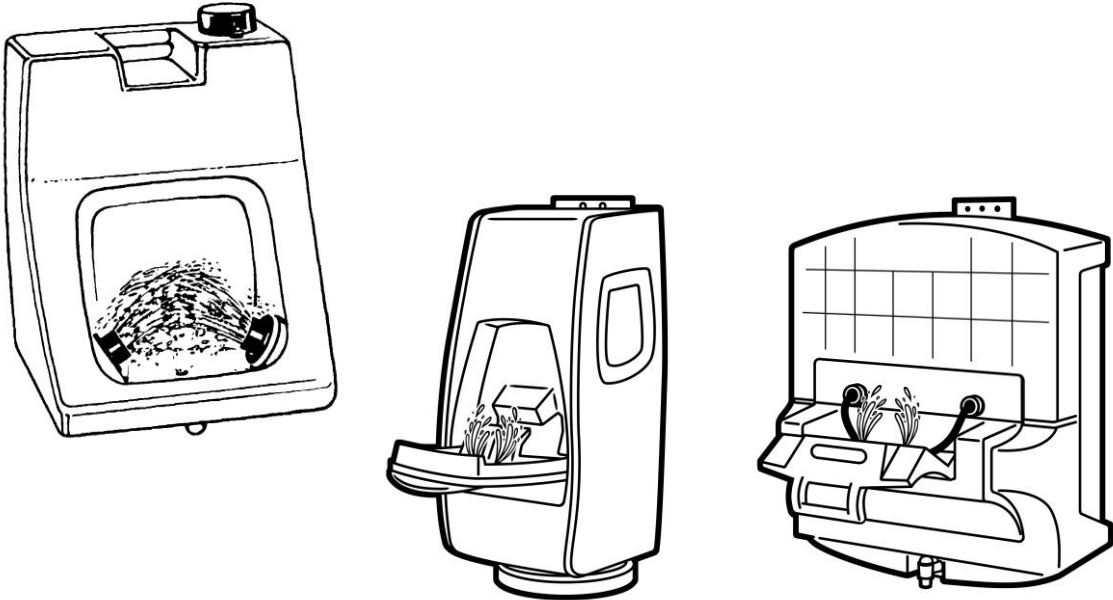

Illustration 5
Non-Pressurized Self-Contained Eyewash

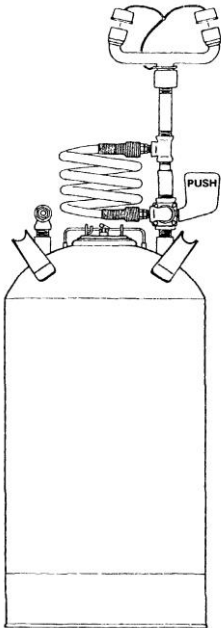

Illustration 6
Pressurized Self-Contained Eyewash

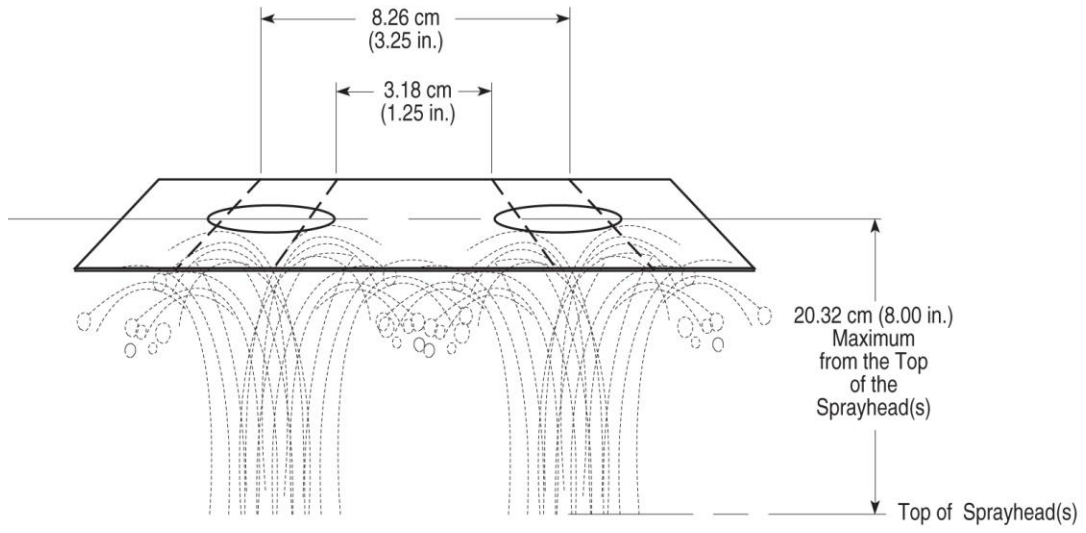

Illustration 7
Typical Eyewash Gauge

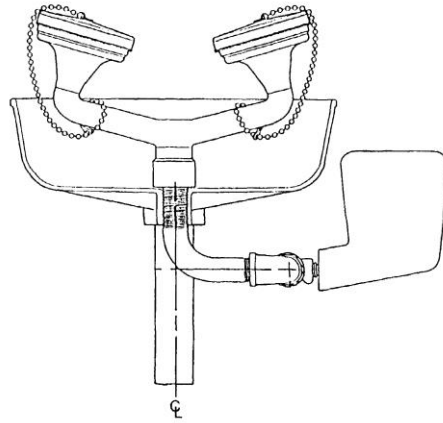

Illustration 8
Eye/Face Wash

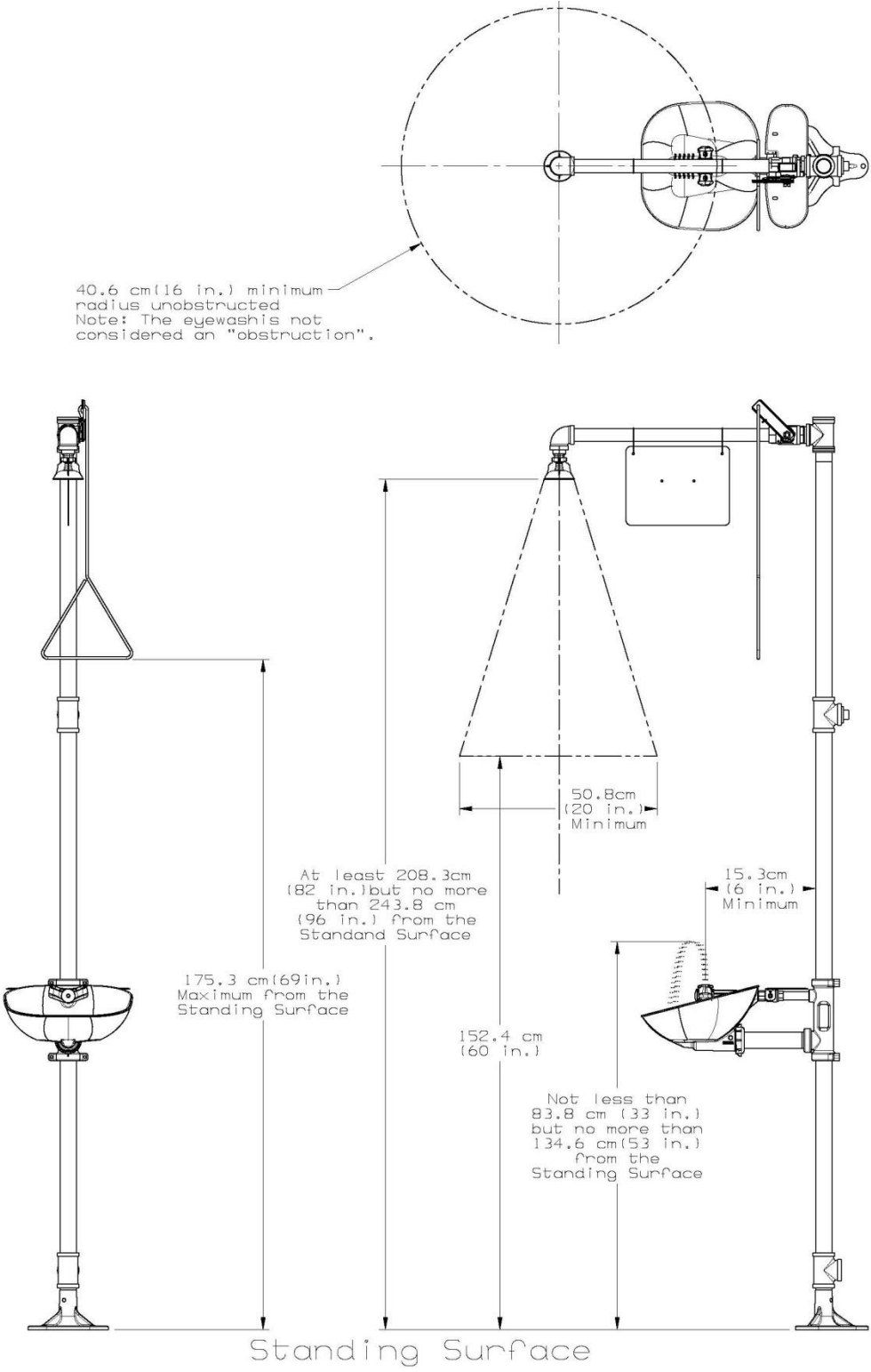

Illustration 9
Combination Unit

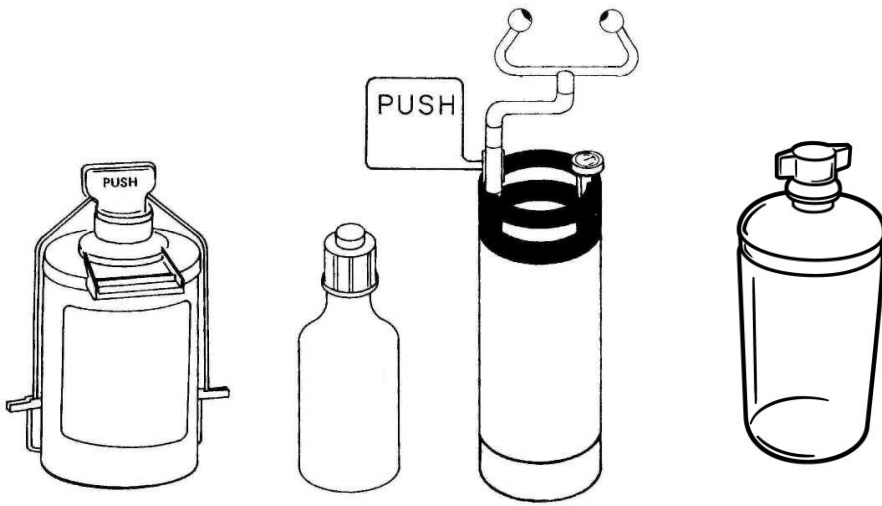

Illustration 10
Personal Wash Units

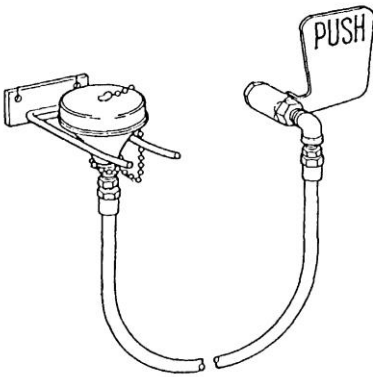

Illustration 11
Drench Hose

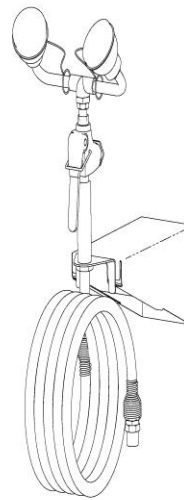

Illustration 12
Drench Hose with Eyewash Attachment

Appendices (The appendices are not part of ANSI/ISEA Z358.1-2014, but are included for information only.)

APPENDIX A – SAFETY CONSIDERATIONS

A1. Personal Wash Unit

The first seconds following an eye injury are often critical to keeping eye injury to a minimum. A personal wash unit may be kept in the immediate vicinity of employees working in a potentially hazardous area. The main purpose of these units is to supply immediate flushing. With this accomplished, the injured individual should then proceed to a plumbed or self-contained eyewash and flush the eyes for the required 15-minute period.

A2. First Aid Practices

A physician or other appropriate professional should provide guidance on specific workplace hazards and should provide instruction on the use of emergency eyewash and shower equipment.

A3. Waste Disposal

Consideration should be given to the proper disposal of waste flushing fluids from operating emergency eyewash and shower equipment. Freezing temperatures, drainage, elevated showers and pollutants are some, but not all, of the considerations. Consult authorities for assistance with applicable local, state and federal regulations.

A4. Personal Protective Equipment

Emergency eyewash and shower equipment is not a substitute for proper primary protective devices. As a defense against flying solid particles and splashing injurious liquids, workers should wear personal protective equipment as needed.

APPENDIX B – INSTALLATION CONSIDERATIONS

B1. Supply Lines

Installation procedures should be in accordance with proper plumbing practices and supply piping adequately sized to meet flow requirements.

B2. Water Capacity

The ANSI/ISEA Z358.1-201x standard includes reference to a flow pressure of 207 kPa (30 psi) only in the certification-related sections for plumbed equipment. This is to ensure that the testing for certification purposes is consistent and that reproducible results can be generated regardless of the laboratory conducting the testing. It is the responsibility of the designer and owner to ensure proper flushing fluid delivery at possible low points of pressure in the plumbing system and to ensure that the plumbed equipment is installed in accordance with the flushing fluid delivery requirements specified by the equipment manufacturer. The weekly activation of plumbed emergency eyewash and shower equipment is to be conducted at normal facility operating pressures. Excess flow pressure can deliver water to the equipment at velocities that could injure the user or render the equipment inoperable. Caution should be exercised with flow pressures over 0.552 kPa (80 psi).

B3. Valve Operation

In the interest of safety, a control valve remaining open is most desirable to allow the user the use of both hands for disrobing or holding the eyes open. However, a self-closing valve may be permitted in a school laboratory situation as a limited exception only where the enforcing authority is of the opinion that the hazard posed is not a serious threat.

B4. Alarm Devices

In addition to the equipment identification required by ANSI/ISEA Z358.1-2014, users may also want to use audible alarms or warning lights to indicate that the unit is in operation. These are particularly important in remote areas. Many companies connect valves electrically to warning lights or buzzers in central dispatch areas to alert the appropriate authorities when the unit is in use.

B5. Placement of Emergency Eyewash and Shower Equipment

Emergency eyewash and shower equipment should be available for immediate use, but in no instance should it take an individual longer than 10 seconds to reach the nearest facility.

There are several factors that might influence the location of emergency facilities. It is recognized that the average person covers a distance of approximately 55 ft. (16.8 m) in 10 seconds when walking at a normal pace. The physical and emotional state of a potential victim (visually impaired, with some level of discomfort/pain, and possibly in a state of panic) should be considered along with the likelihood of personnel in the immediate area to assist. The installer should also consider other potential hazards that may be adjacent to the path of travel that might cause further injury. A single step up into an enclosure where the equipment can be accessed is not considered to be an obstruction. Additionally, installers should allow for adequate overhead clearance to accommodate the presence of cabinets over counter- or faucet- mounted emergency eyewashes, so as not to create an additional hazard that could be encountered when using the device.

A door is considered to be an obstruction. Where the hazard is not corrosive, one intervening door can be present so long as it opens in the same direction of travel as the person attempting to reach the emergency eyewash and shower equipment and the door is equipped with a closing mechanism that cannot be locked to impede access to the equipment.

In situations that might warrant the placement of emergency eyewash and shower equipment close to the hazard, such as exposure to highly corrosive chemicals, the appropriate professional should be contacted for advice on the proper distances. Equipment should be located adjacent to the hazard, but situated in such a manner such that exposure to the splash hazard or other hazards (e.g., exposed electrical conductors) does not occur while using the eyewash.

B6. Delivered Flushing Fluid Temperature

Continuous and timely irrigation of affected tissues for the recommended irrigation period are the principal factors in providing first aid. Providing flushing fluid at temperatures conducive to use for the recommended irrigation period is considered an integral part of providing suitable facilities. Medical recommendations suggest a flushing fluid at tepid temperatures be delivered to affected chemically-injured tissue. Temperatures in excess of 38°C (100°F) have proven to be harmful to the eyes and can enhance chemical interaction with the skin and eye tissue. Consideration should be given to the impact of isolated ambient temperature changes. Colder ambient temperature might require an enclosure for added protection. Warmer ambient temperature might require a re-evaluation of the water temperature.

While cold flushing fluid temperatures provide immediate cooling after chemical contact, prolonged exposure to cold fluids affect the ability to maintain adequate body temperature and can result in the premature cessation of first aid treatment. Recent information indicates that a temperature of 16°C (60°F) is suitable for the lower parameter for tepid flushing fluid without causing hypothermia to the equipment user.

B7. Weekly Activation for Plumbed Emergency Eyewash and Shower Equipment

The intent of the weekly activation to be conducted on plumbed emergency eyewash and shower equipment is to ensure that there is a flushing fluid supply at the head of the device and to clear the supply line of any sediment build-up that could prevent fluid from being delivered to the head of the device and minimize microbial contamination due to stagnant water. The duration of this test is dependant on the volume of water contained in the unit itself and all sections of pipework that do not form part of a constant circulation system (also known as “dead leg” portions). Water in these sections is stagnant until a flow is activated by opening a valve. The goal is to flush out stagnant water in the dead leg completely. Where mixing valves are used, both the hot water and cold water supplies to the valve must be considered.

REFERENCES

Independent study results: Placement Dimension Verification, provided by Anthrotech, Yellow Springs, OH, 2002

ASPE Plumbing Engineering Design Handbook Vol. 4, Chapter 1, American Society of Plumbing Engineers, 2012

Emergency Eyewash and Shower Equipment: A Comprehensive Literature Review and Comparison, American Society of Plumbing Engineers Research Foundation, 2008

Clinical Ophthalmology, Harper & Row, 1992, Vol. 2, Chapter 21

Human Engineering Guide to Equipment Design, Woodson, W. E. and Conover, D. W., Army, Navy, Air Force Steering Committee, United States Government, 1972

Human Engineering Guide for Equipment Designers, University of California Press, 1964, 2nd ed.

United States Air Force Flight Surgeon's Manual, Chapter 20, 1991, Third ed.

United States Coast Guard lifesaving and fire safety standards for commercial ships and recreational boats – Cold Water Survival